

A96

Electromechanical submersible level controls for hazardous areas liquids

Suitable to control directly diesel oil level (polyurethane version) or high temperatures liquids (silicone version).

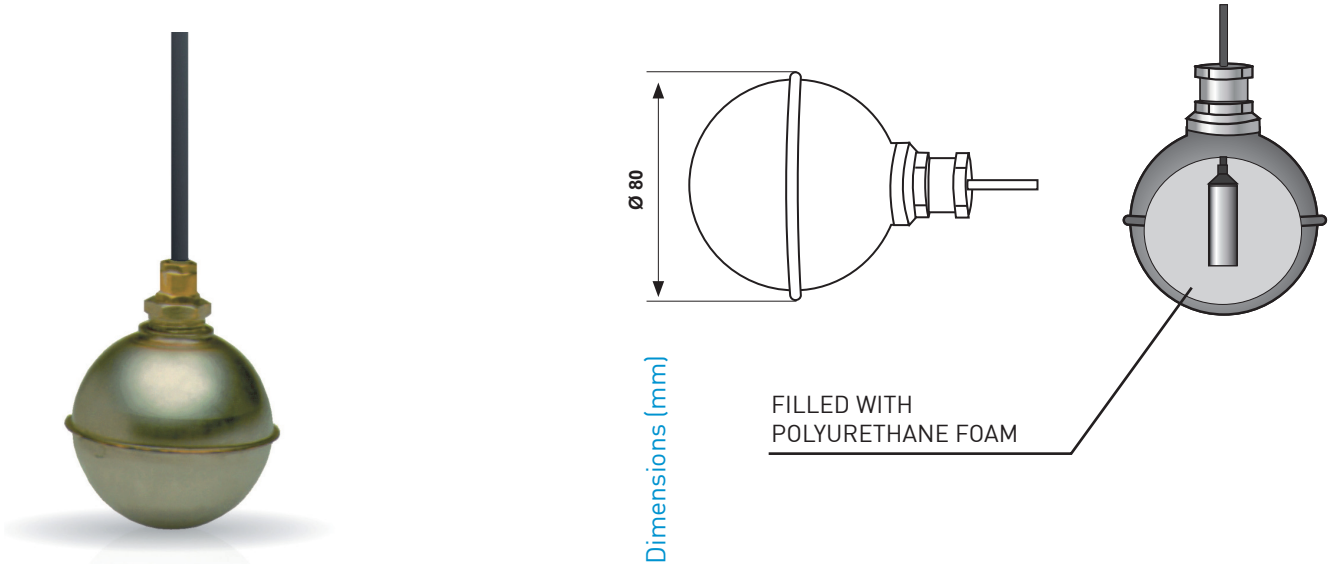

	Cable type	Cable length mt	Contacts rating	Maximum pressure	Maximum liquid temperature	Protection degree	Availability
A96C	polyurethane	5	5A 250 Vca	4 bar	60 °C	IP68	in stock
A96D	polyurethane	15	5A 250 Vca	4 bar	60 °C	IP68	in stock
A96E	silicone	5	5A 250 Vca	4 bar	130 °C	IP68	on request
A96G	silicone	15	5A 250 Vca	4 bar	130 °C	IP68	on request

ELECTRICAL FEATURES

The switch consists from a steel vessel with mercury (AISI 304 sensor).

Suitable to control contactor coil.

Isn't suitable to control directly the motor.

Electrical cable section 2x1 mm² + ground connection.

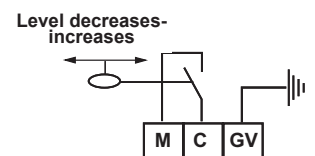

ELECTRICAL WIRING FOR EMPTYING PUMP

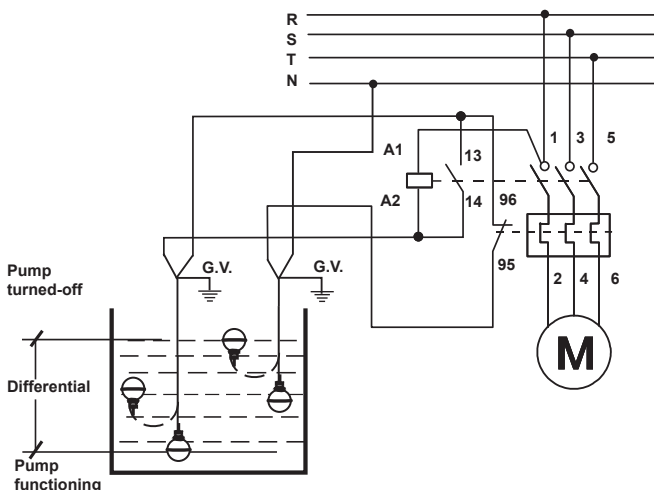

HOMOLOGATION AND STANDARDS

Complies with EN 60730-2-16 standards.

OPERATION

For minimum or maximum level monitoring one level control is used.

To determine a differential level higher than 1,5-2 cm two level controls are used, one for the maximum and one for minimum level.

FEATURES

Submersible sealed float.

External float body made of AISI 304 stainless steel.

Internal casing of the device filled with polyurethane foam.